



Guide: Handling of tactile resistance temperature sensors

Temperature resistance sensors are transducers that have a manufacturer-specific temperature time constant. Sensors are subject to a calibration interval.

This guarantees that their sensors operate within the specified parameters.

To guarantee a long period of use of your purchased temperature sensor, we have decided to compile a small guide to avoid costly repairs.

General structure of a temperature resistance sensor with measuring cable

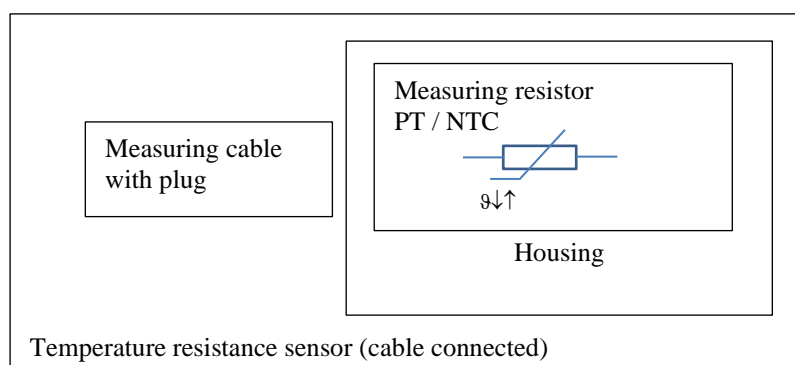

Notes on handling sensors

Cables, connectors and housings

- Avoid kinking the measuring cables
 - Unroll the measuring cable completely. (do not form loops)
 - Sensors must not be exposed to strong electromagnetic fields
 - Avoid mechanical tension on measuring cables (do not pull, push or squeeze)
 - Ambient medium should not be acidic or basic in any form, this can lead to corrosion of the housing and cables.
 - Avoid strong UV-light radiation, especially with plastic based housings. This leads to decomposition, which could damage your sensors.
 - Mechanical influences must not affect the sensor housing, as this can deform the active sensor surface. This could lead to changes in the contact resistances.
 - Tactile temperature sensors best map the temperature by making the measuring surfaces as flat as possible. (It may also be helpful to use thermal conductive paste/foils which have a high coefficient of thermal conductivity. These should be inserted between the measuring surface and the sensor surface).
 - With air / gas / liquid sensors the flow should be as laminar as possible. Turbulences should be avoided.
 - Dirty environments should be avoided. If necessary, the measuring surfaces should be cleaned
 - Observe ambient temperature.
- The cables, especially with PUR & PVC, are designed for a narrow temperature range.



Teflon – cable (PTFE):	not moved: moving:	-190°C ... +260°C -25°C ... +260°C
PUR - cable:	not moved: moving:	-40 ... +90 °C -5 ... +90 °C
PVC - cable:	not moved: moving:	-40 ... 70°C -5 ... 70°C
Glass silk - cable:	not moved: moving:	-50 ... +400°C -50 ... +400°C

Therefore, as users, you may need to define protective measures:

- additional temperature insulation of the cables.
- UV protection shafts (cable ducts, safety walls etc.)
- Housing materials can also be used as insulators. Here the materials used are partly made of plastic. Therefore, they should not have higher / lower temperatures than the specified temperature ranges (see data sheet).
- The number of plug cycles is limited: In spite of the high specifications we have received from the manufacturer, frequent replugging should be avoided, as abrasion leads to a change in contact resistance. This can be compensated by a recommended recalibration interval of two years. We will be pleased to send you an offer or a reminder if you wish to receive one. Our plug contacts are hard gold-plated - coated, this prevents corrosion resistance and keeps contact resistance as low as possible. Furthermore, our plugs have an anti-twist protection. (see picture below)
- Observe regular calibration intervals recommended by the manufacturer

Please make sure that you do not force the LEMO plug of your sensor into the TEMP socket of your evaluation unit. But according to the illustrated scheme:

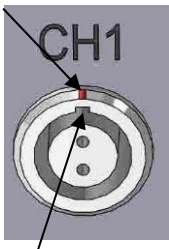
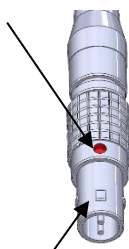
Connecting the sensor plug and socket

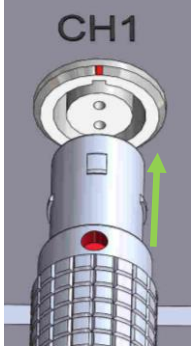
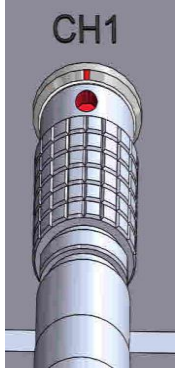
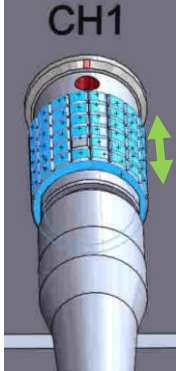
Socket	Plug		Socket - Plug		
<p>Colour marking</p>  <p>CH1</p> <p>Nose</p>	<p>Colour marking</p>  <p>Nose</p>	 <p>open</p>	 <p>CH1</p>	 <p>CH1</p>	 <p>CH1</p>
			<p>Procedure: Plugging in</p>		<p>Procedure: unplug</p>

If you exercise care and observe the above points, you will enjoy your sensors for a long time.